



**OWNER'S MANUAL
BAIL RETAINER f/#495
#495-10**

Place the fixed end of the bail retainer into the retainer hole on one of the bail eyes. Orient the retainer assembly similar to diagram. Apply thread lock adhesive (Loctite243 or similar) to bolt and secure the fixed end with the bolt and washer. Tighten to 80 in*lbs. Allow adhesive to cure before placement into service. The Bail Retainer is intended to temporarily support the bails of the Rescue Basket (#495) in the up position prior to attachment of the hoist hook and after removal of the hoist hook. To engage, insert the retainer pin located on the free end of the retainer cable into the small hole on the opposite bail assembly. Allow the toggle to drop down, thereby securing the pin. Always attach the hoist hook through the bail eyes prior to moving or hoisting the rescue basket. To disengage the bail retainer, press-in on the retainer pin compressing the coil spring. Lift or rotate the toggle so that it is parallel to the pin and then pull the pin out. Carefully stow the bail assemblies.

WARNINGS & CAUTIONS

- o Do not move or lift the rescue basket with only the bail retainer supporting the bail assembly.
- o Do not lift the basket by the bail retainer.
- o Secure the helicopter hoist hook through both lifting eyes of the bail assembly.

WARRANTY

LSC products are warranted to the first consumer purchaser to be free from defects in material or workmanship for a period of twelve (12) months. Please contact LSC for our complete Warranty information and Policies, or visit our website.

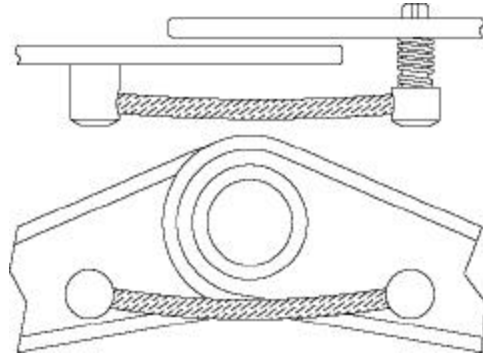

LIFESAVING SYSTEMS CORP.
220 ELSBERRY RD.
APOLLO BEACH, FL 33572
PHONE: 813/645-2748
FAX: 813/645-2768
www.lifesavingsystems.com

*Lifesaving Systems Corp.
#F-750-495-10 OM (Rev A) Updated 2011-10-10*



**OWNER'S MANUAL
BAIL RETAINER f/#495
#495-10**

Place the fixed end of the bail retainer into the retainer hole on one of the bail eyes. Orient the retainer assembly similar to diagram. Apply thread lock adhesive (Loctite243 or similar) to bolt and secure the fixed end with the bolt and washer. Tighten to 80 in*lbs. Allow adhesive to cure before placement into service. The Bail Retainer is intended to temporarily support the bails of the Rescue Basket (#495) in the up position prior to attachment of the hoist hook and after removal of the hoist hook. To engage, insert the retainer pin located on the free end of the retainer cable into the small hole on the opposite bail assembly. Allow the toggle to drop down, thereby securing the pin. Always attach the hoist hook through the bail eyes prior to moving or hoisting the rescue basket. To disengage the bail retainer, press-in on the retainer pin compressing the coil spring. Lift or rotate the toggle so that it is parallel to the pin and then pull the pin out. Carefully stow the bail assemblies.

WARNINGS & CAUTIONS

- o Do not move or lift the rescue basket with only the bail retainer supporting the bail assembly.
- o Do not lift the basket by the bail retainer.
- o Secure the helicopter hoist hook through both lifting eyes of the bail assembly.

WARRANTY

LSC products are warranted to the first consumer purchaser to be free from defects in material or workmanship for a period of twelve (12) months. Please contact LSC for our complete Warranty information and Policies, or visit our website.

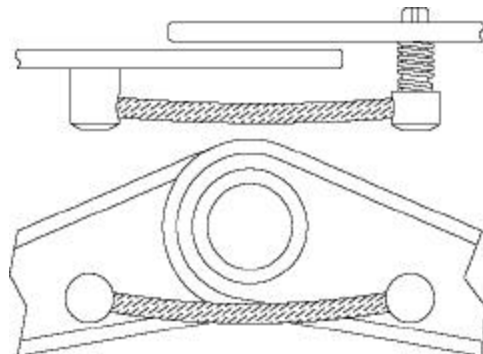

LIFESAVING SYSTEMS CORP.
220 ELSBERRY RD.
APOLLO BEACH, FL 33572
PHONE: 813/645-2748
FAX: 813/645-2768
www.lifesavingsystems.com

*Lifesaving Systems Corp.
#F-750-495-10 OM (Rev A) Updated 2011-10-10*