



OWNER'S MANUAL

RESCUE BASKET

#499-B

INSPECTION

Every 30 days, and after each use, carefully inspect the following:

1. All four hinge points, bail assemblies and lifting eyes for damage, deformation, cracks, and severe corrosion.
2. Frame assembly and bails for broken welds, bends (deformation), corrosion and abrasion.
3. Check float covers, floats and plastic net liner for cuts, tears, abrasion and any other visible damage. Repair or replace as required.
4. Examine the bail retainer components. Check the retainer pin and cable for damage and corrosion. Check for loose attachment hardware.

Remove basket from service if inspection identifies any damage or abnormal conditions indicated above. Repair or replace basket accordingly.

BAIL RETAINER INSTRUCTIONS

The Bail Retainer is intended to temporarily support the bails of the Rescue Basket in the up position prior to attachment of the hoist hook and after removal of the hoist hook. To engage, insert the retainer pin located on the free end of the retainer cable into the small hole on the opposite bail assembly. Allow the toggle to drop down, thereby securing the pin. Always attach the hoist hook through the bail eyes prior to moving or hoisting the rescue basket. To disengage the bail retainer, press-in on the retainer pin compressing the coil spring. Lift or rotate the toggle so that it is parallel to the pin and then pull the pin out. Carefully stow the bail assemblies.

WARNINGS & CAUTIONS

- o Do not move or lift the rescue basket with only the bail retainer supporting the bail assembly.
- o Do not lift the basket by the bail retainer.
- o Secure the helicopter hoist hook through both lifting eyes of the bail assembly before moving or hoisting the rescue basket.

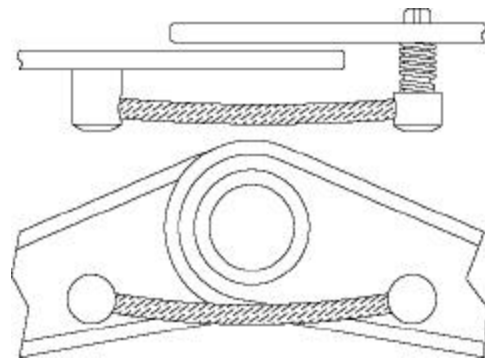

REPAIR & MAINTENANCE

All weld repairs shall be TIG welded by qualified welders only. **Only** minor repairs should be performed in the field.

1. After use or as required, thoroughly wash the entire basket with fresh, soapy water. Flush clean, fresh water through all hinge points. Allow basket to thoroughly dry. Lubricate the bail hinge points (4 each) and the drop-down toggle of the bail retainer pin with light machine oil. Check attachment bolt on the bail retainer for tightness. Remove any loose item, clean the screw threads, apply thread-locking compound and reinstall the hardware. Tighten the attachment bolt to 80 in*lbs.
2. **IMPORTANT:** Damage to tubular frame members and welds, shall be reviewed by the manufacturer for repair and serviceability determination.

REPLACEMENT PARTS

#499-1	Plastic Net Liner, EA.	#495-03	Spreader Bar, Float
#499-2	Floats w/Covers, Pair	#495-10	Bail Retainer
#499-3	Floats Covers, Pair	#H099	Stainless Screw, Spreader Bar
#499-BGT	Bail Guard Tape	#H100	Stainless Lock Nut, Spreader Bar

WARRANTY

LSC products are warranted to the first consumer purchaser to be free from defects in material or workmanship for a period of twelve (12) months. Please contact LSC for our complete Warranty information and Policies, or visit our website.

LIFESAVING SYSTEMS CORP.

220 ELSBERRY RD.
 APOLLO BEACH, FL 33572
 PHONE: 813/645-2748
 FAX: 813/645-2768

www.lifesavingsystems.com